

Deck Construction Guide for Detached and Semi-detached Dwellings

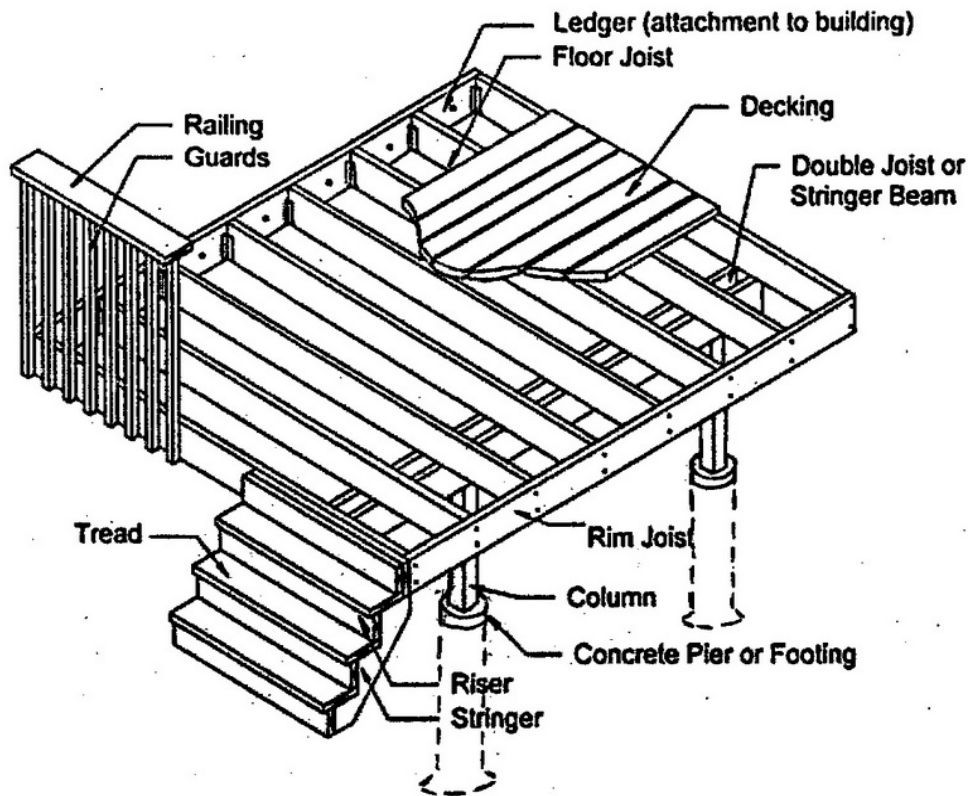

General Requirements

A Building Permit is required for all decks except where:

- Distance from the finished ground to the finished deck is not more than 24" and
- The deck is not supporting a roof

Note: A deck must comply with the building code and zoning requirements. For more information, contact The City of Oshawa's Building Department at 905-436-5658.

Designers Qualification and Registration Requirements:

Homeowners submitting designs for their own residence are exempt from qualification and registration requirements, however, individuals and agencies providing design services to the public have to meet the qualifications and registration requirements set out by the Ministry of Municipal Affairs and Housing. You can confirm the qualification and registration status of your designer by referring to the ministry's on-line qualification and registration system (QuARTS).

Application Requirements:

- Completed building permit application forms
- Two copies of the most recent survey or site plan for the property showing dimensions of all existing buildings and structures, and their setbacks drawn to scale. The proposed deck is to be plotted on the site plan and setback dimensions to all property lines are to be shown. (see attached sample site plan on page 5)
- Two copies of construction drawings including structure, elevation, section and details drawn to scale. The attached template drawing and details could be used, providing all dimensions and information are shown on the "Deck Framing Plan" (page 4).
- The current minimum permit fee, payable at time of application by cheque (payable to "City of Oshawa"), cash, debit, Visa, MasterCard, or American Express

Call before you dig:

It is the owner's/contractor's responsibility to call the utility companies to locate any underground utility lines within the construction zone to avoid damaging them during construction.

Ontario One Call

1-800-400-2255

Step by Step Instructions

1. Start by filling in the following information on the blank area shown on “Deck Framing Plan” (Page 4). Overall length and width of deck, length of landing and stair, pier spacing, joist span and maximum height of the deck above grade.
2. Once you have your joist span, and pier spacing you can size each component of the deck using Tables 1 and 2 below.
3. The pier size is in the intersecting box of the row that corresponds with your joist span and the column that corresponds with your pier spacing.
4. The beam size is in the intersecting box of the row that corresponds with your joist span and the column that corresponds with your pier spacing.
5. Joist size is in the intersecting box of the row that corresponds with your joist span and the column labeled joist size.
6. Fill out all the above information on the “Deck Framing Plan” (Page 4) and submit two copies of this page and all attached applicable details with the rest of the documents required for your permit application.

Notes: Please provide your own deck framing plan if your deck layout is different from what is shown in this package (Use the same concept and provide the same information). You will also need to provide your own details if the proposed construction methods differ than those provided.

Any proposed prefabricated guard/railing system must have a set of stamped details provided by a licensed Engineer with the Province of Ontario (a manufacturer or building supply store would supply you these details at your request).

Table 1- Pier Size (diameter at base Ø)

Joist Span	4 feet pier spacing	6 feet pier spacing	8 feet pier spacing	10 feet pier spacing	Joist Size
6 feet	8 in. Ø	10 in. Ø	12 in. Ø	12 in. Ø	2 x 6*
8 feet	10 in. Ø	12 in. Ø	12 in. Ø	14 in. Ø	2 x 6*
10 feet	10 in. Ø	12 in. Ø	14 in. Ø	16 in. Ø	2 x 8
12 feet	12 in. Ø	14 in. Ø	16 in. Ø	18 in. Ø	2 x 10

* 2X8 joists required for wood railing support as per SB-7 of the Ontario Building Code

Table 2 – Beam Size

Joist Span	4 feet pier spacing	6 feet pier spacing	8 feet pier spacing	10 feet pier spacing	Joist Size
6 feet	2 – 2 x 6	2 – 2 x 6	2 – 2 x 8	2 – 2 x 10	2 x 6*
8 feet	2 – 2 x 6	2 – 2 x 8	2 – 2 x 10	2 – 2 x 12	2 x 6*
10 feet	2 – 2 x 6	2 – 2 x 8	2 – 2 x 10	2 – 2 x 12	2 x 8
12 feet	2 – 2 x 6	2 – 2 x 8	2 – 2 x 10	2 – 2 x 12	2 x 10

* 2X8 joists required for wood railing support as per SB-7 of the Ontario Building Code

Notes: Soil bearing capacity to be considered as 2090 PSF (100kPa) unless otherwise determined by a Building Inspector.

Wood posts:

- 4 ft. x 4 ft. for deck heights up to 5 feet on minimum 8 inch sono tubes
- 6 ft. x 6 ft. for deck heights above 5 feet on minimum 10 inch sono tubes

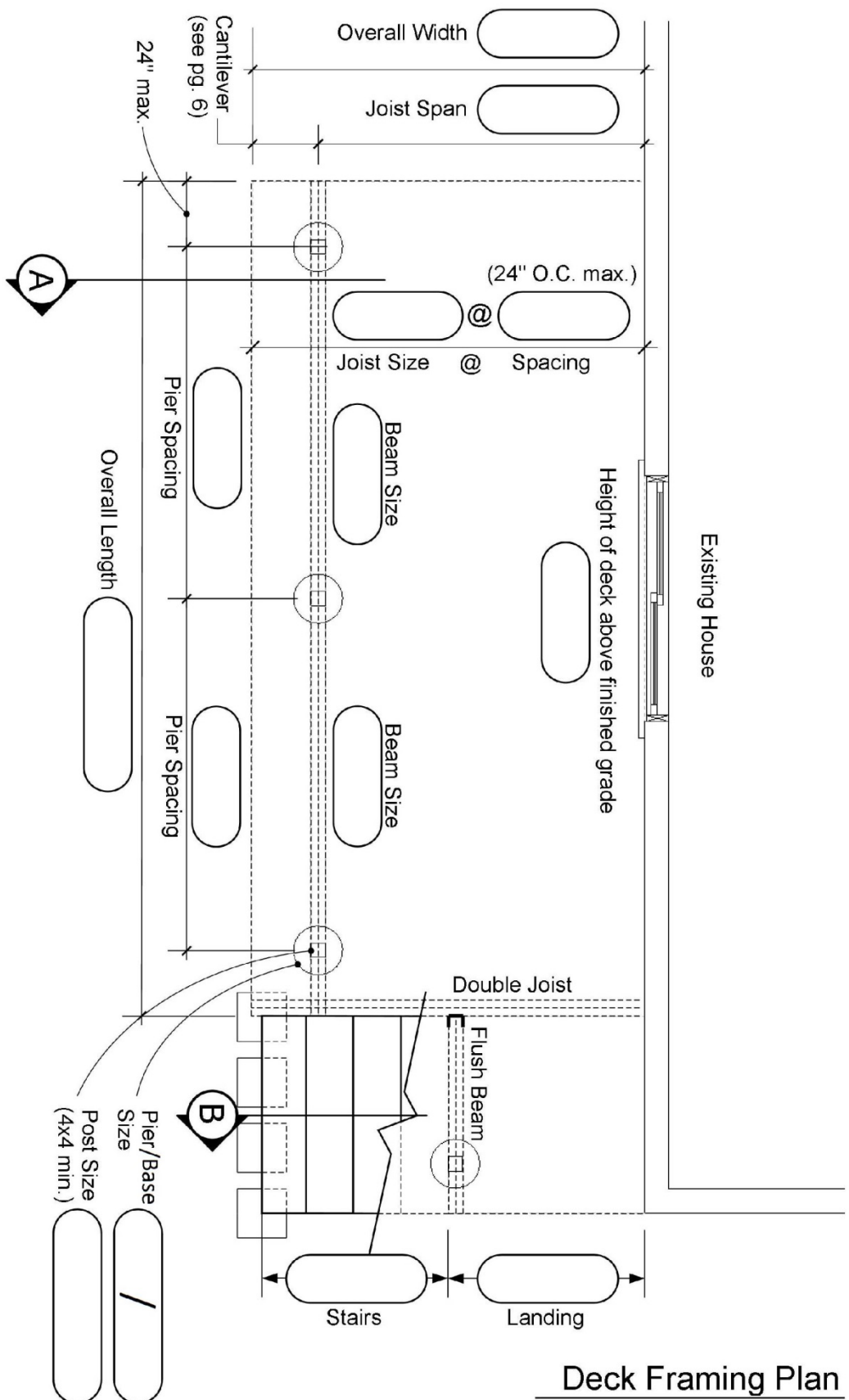

- Guard Construction:** Please check one and supply details if required
- Cantilevered guard as per details ED1, ED2 & ED5
 - Post & Rail guard as per details EB2
 - Other (provide details)

Deck Framing Plan

Scale: NTS 4

"It is the responsibility of owner(s) to provide accurate site information for building permit applications including dimensions, lot area and locations of property lines, easements, right of ways, etc."

Sample Site Plan:

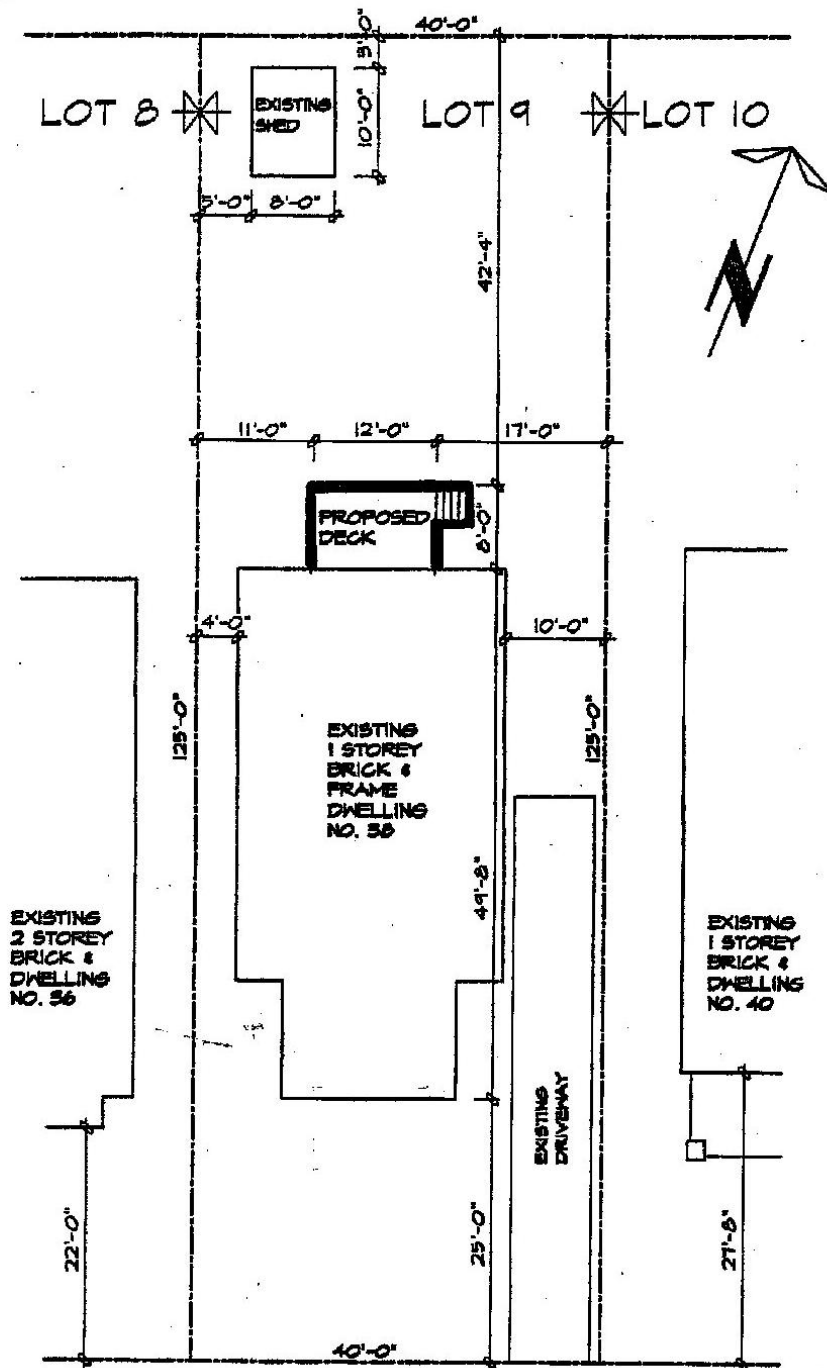

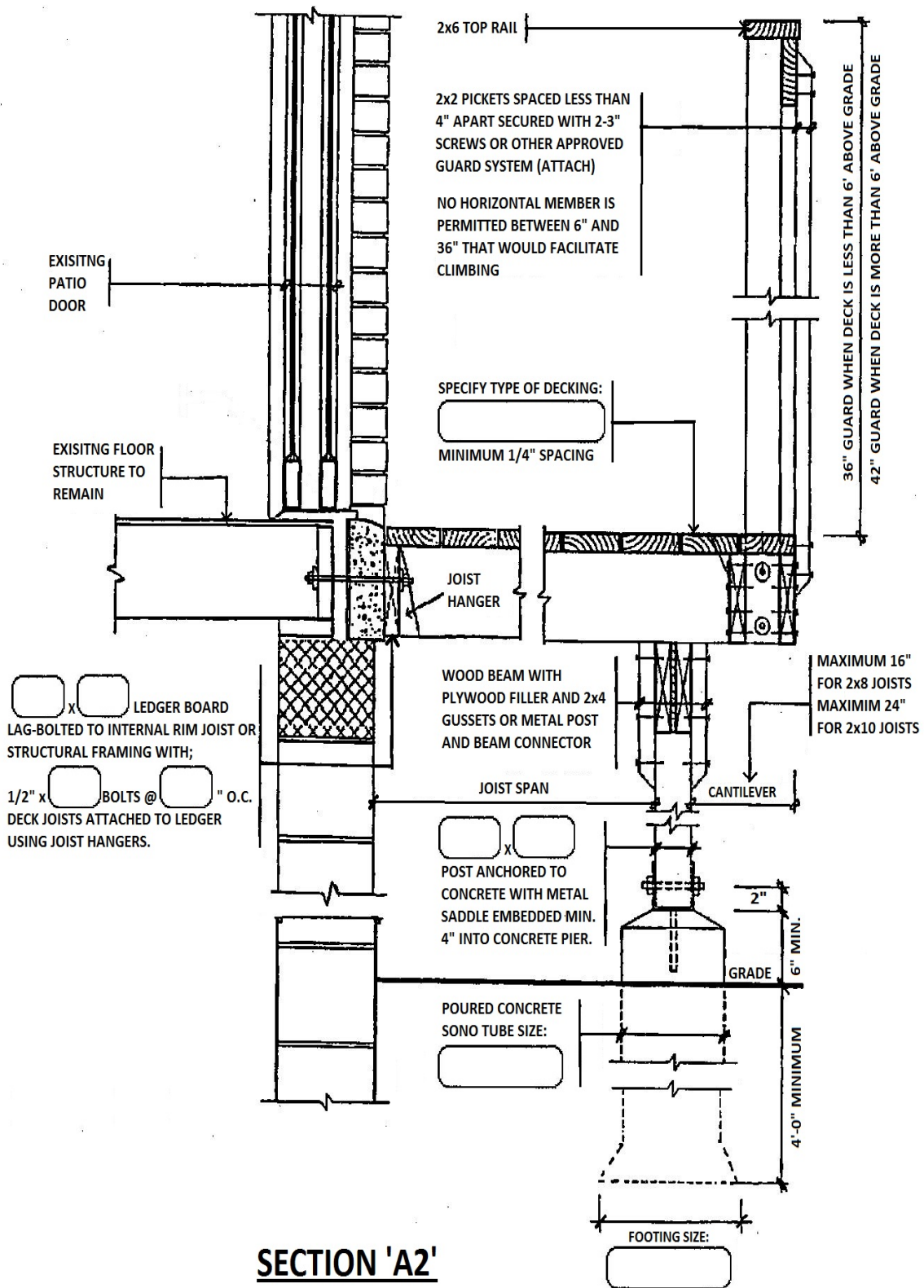

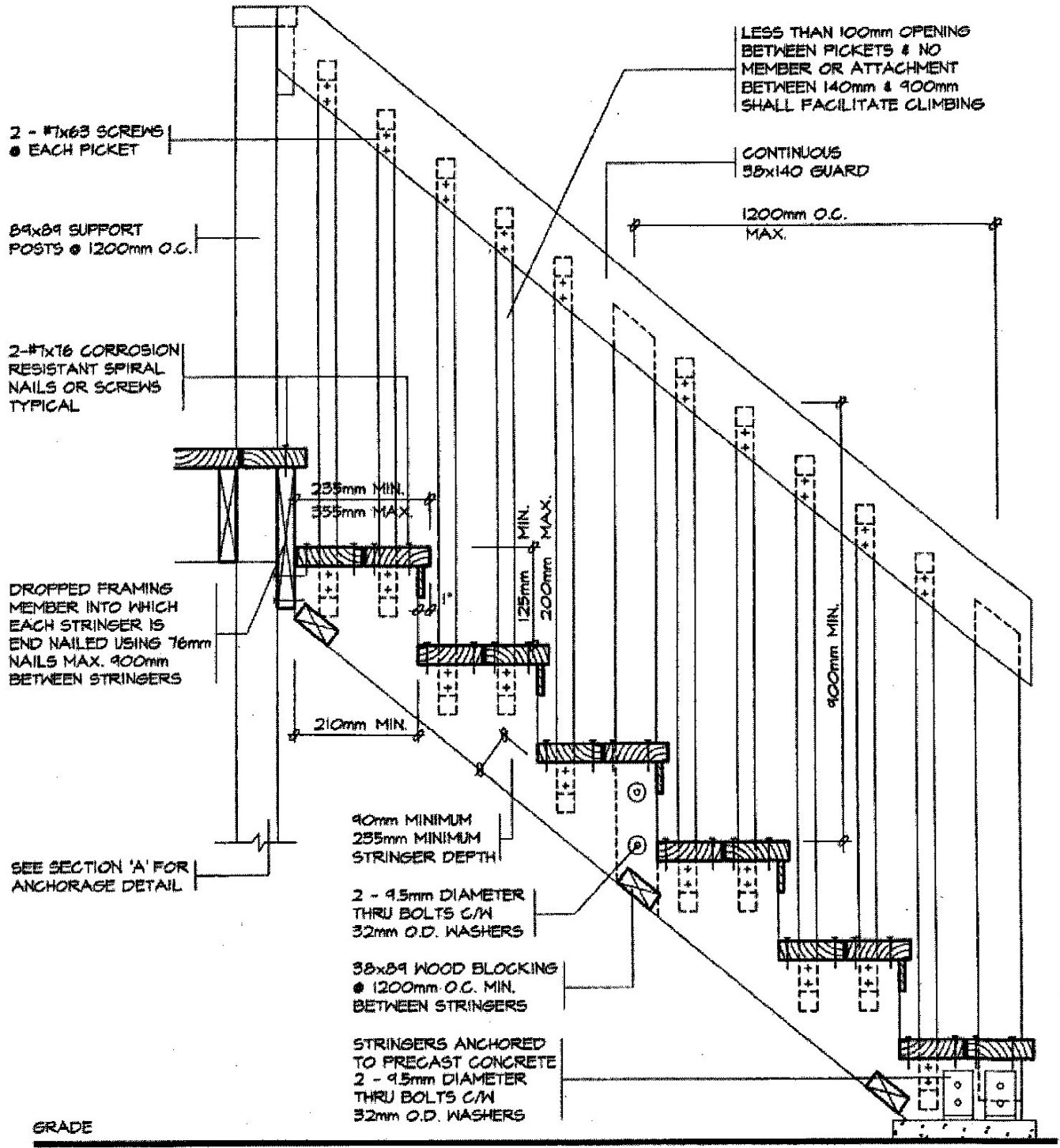

SECTION 'B'

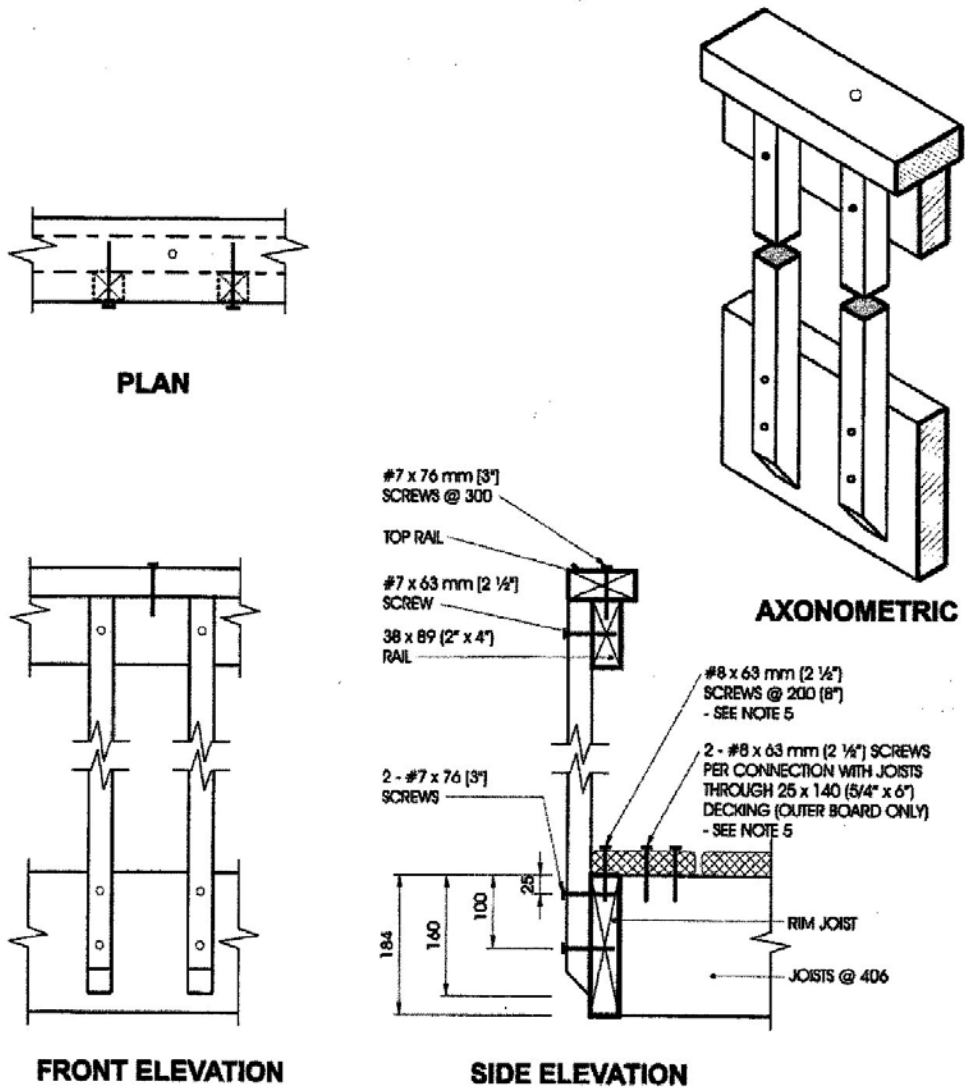

Detail ED-1

Exterior Connection: Cantilevered Picket Screwed to Rim Joist

Notes:

1. Provide a suitable post, return, or solid support at each end of the guard.
2. Wood for cantilevered pickets shall be Douglas Fir-Larch, Spruce-Pine-Fir, or Hem-Fir Species.
3. Fasten rim joist to each floor joist with 3 - 82 mm (3 1/4") nails.
4. Dimensions shown are in mm unless otherwise specified.
5. The outer deck board shall not be less than 140 mm (6" nominal) wide. Where 38 mm (2" nominal) thick boards are used, the length of the wood screws shall be not less than 76 mm (3").

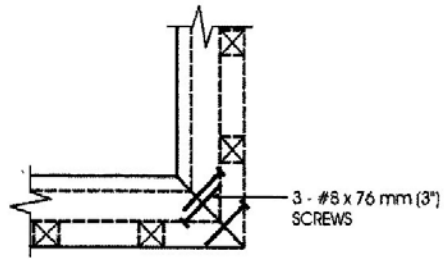

PLAN TOP RAIL

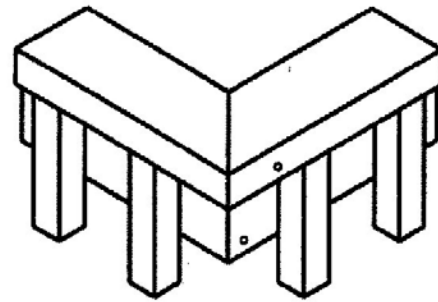

AXONOMETRIC

ONE FASTENER IN HORIZONTALLY ORIENTATED PORTION OF TOP RAIL
AND TWO IN VERTICALLY ORIENTATED PORTION.

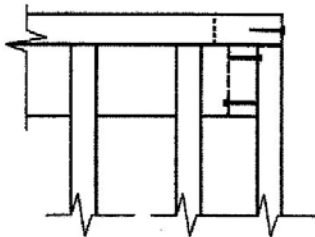

FRONT TOP RAIL

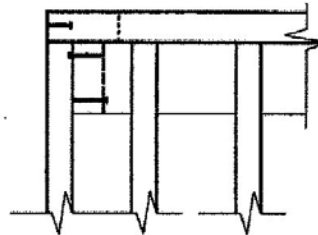

SIDE TOP RAIL

Detail ED-5

Exterior Connection: Corner Joint

Notes:

1. Screws fastening pickets are omitted for clarity.
2. Provide a minimum of 10 pickets beyond the return if end restraint of the guard is provided by this return detail only.

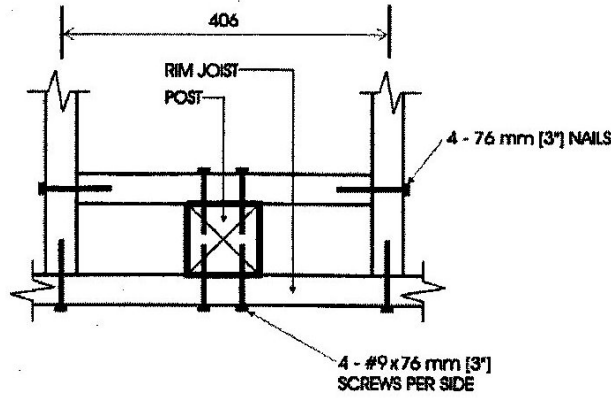

PLAN

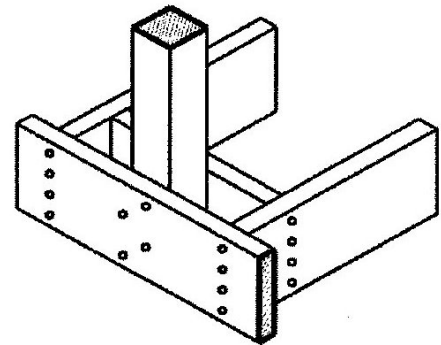

AXONOMETRIC

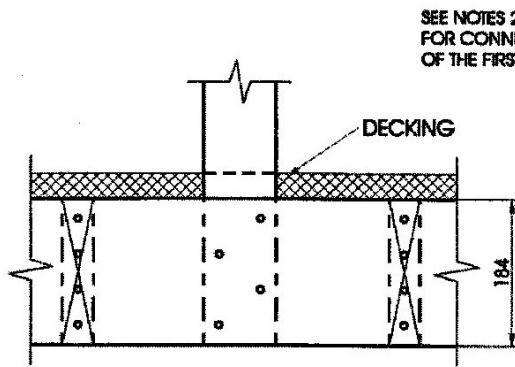

FRONT ELEVATION

SEE NOTES 2 & 3
FOR CONNECTION
OF THE FIRST BOARD

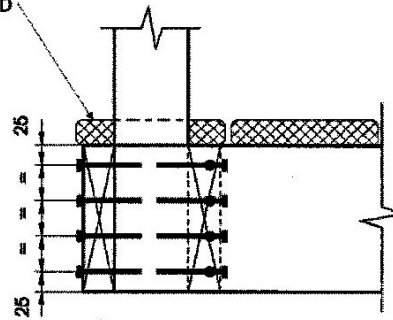

SIDE ELEVATION

Detail EB-2

Exterior Connection: Post Screwed to Rim Joist

Notes:

1. Decking is omitted from the plan view and the axonometric view for clarity.
2. Fasten 25 mm x 140 mm (⁵/₁₆" x 6" nominal) outer deck board to rim joist with 63 mm (2½") nails at 300 mm (12").
3. Fasten 25 mm x 140 mm (⁵/₁₆" x 6" nominal) outer deck board to floor joist with 1 - 63 mm (2½") nail at each joist.
4. The post may be positioned anywhere between the joists.
5. #9 screws may be replaced by #8 screws if the maximum spacing between posts is not more than 1.20 m (3'-11").
6. Dimensions shown are in mm unless otherwise specified.

MAXIMUM SPACING BETWEEN POSTS	
Species	Maximum Spacing, m (ft-in)
Douglas Fir-Larch, Hem-Fir, Spruce-Pine-Fir	1.56 (5'-1")
Northern Species	1.20 (3'-11")
Column 1	2

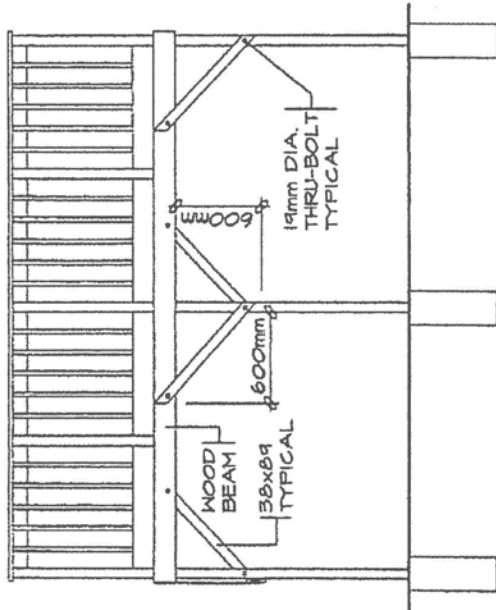

BRACING PARALLEL TO BEAM

FREE STANDING DECKS GREATER THAN 600mm ABOVE GRADE SHALL RESIST LATERAL LOADING & MOVEMENT. ALL POSTS MUST BE BRACED WHERE THE SUPPORTED AREA EXCEEDS THOSE LISTED IN THE TABLE 1

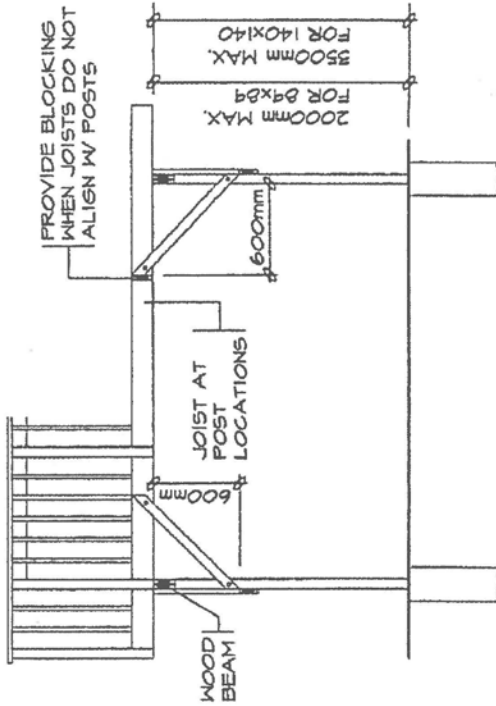

BRACING PERPENDICULAR TO BEAM

GENERAL NOTES

1. SITE PLAN OR SURVEY IS REQUIRED SHOWING ALL LOT LINES & DIMENSIONS SIZE & LOCATION OF ALL EXISTING BUILDINGS, LOCATION & SIZE OF DECK
2. LUMBER NO. 2 SPF OR BETTER, WOOD POSTS MIN. 84x84 (SOLID). USE CORROSION RESISTANT SPIRAL NAILS OR SCREWS.
3. DECK IS NOT PERMITTED TO BE SUPPORTED ON BRICK VENEER
4. CONCRETE PIERS SHALL BEAR ON UNDISTURBED SOIL. THE BEARING CAPACITY OF THE SOIL SHALL BE DETERMINED PRIOR TO CONSTRUCTION
5. PROVIDE A HANDRAIL 900mm HIGH ON STAIRS IF MORE THAN THREE RISERS.
6. FOR SUPPORTED AREAS WHICH EXCEED THOSE LISTED IN THESE TABLES THE POSTS SHALL BE BRACED AS SHOWN ABOVE.
7. MAXIMUM HEIGHT REFERS TO THE HEIGHT OF THE POST FROM THE TOP OF THE PIER TO THE DECK SURFACE

9.8.8.5. DESIGN TO PREVENT CLIMBING

Exterior guards serving residential occupancies shall be designed in accordance with this Article to prevent climbing by unattended children.

Horizontal, diagonal or decorative grille work, upturned curbs exposing ledges and similar constructions are not permitted within an area located between 100 mm and 900 mm above the floor or walking surface.

